

Specialty Products™

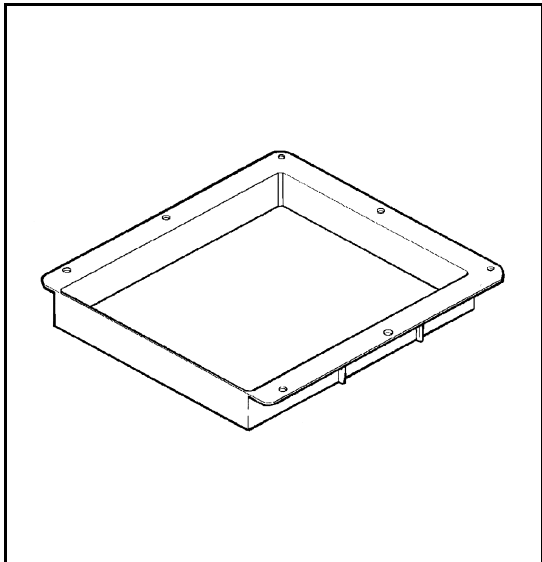

STOKES® TUB DAM Specification Sheet

PART NO.	DESCRIPTION
P-3092	Tub Dam 1-1/2"

FRONT



SIDE

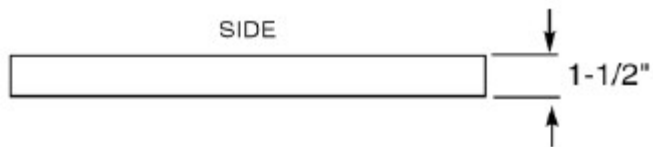

SPECIFICATION

Furnish and install Stokes™ Tub Dam to form cavity for tub waste and overflow connection in lightweight concrete decks as manufactured by LSP Products Group/Specialty Products.

DESIGN FEATURES

- Constructed of high impact plastic to resist corrosion and cracking during construction.
- One-piece construction simplifies installation.
- Use in all types of residential construction.



3689 Arrowhead Drive, Carson City, NV 89706

Phone (800) 854-3215 Fax (800) 243-1777

E-mail sales@lspproducts.com Website www.lspproducts.com

SP/S-2005 (03-02)

Product Submittal	
Job Name	
Date	
Part Number	Quantity
Architect	
Contractor	