

Specialty Products™

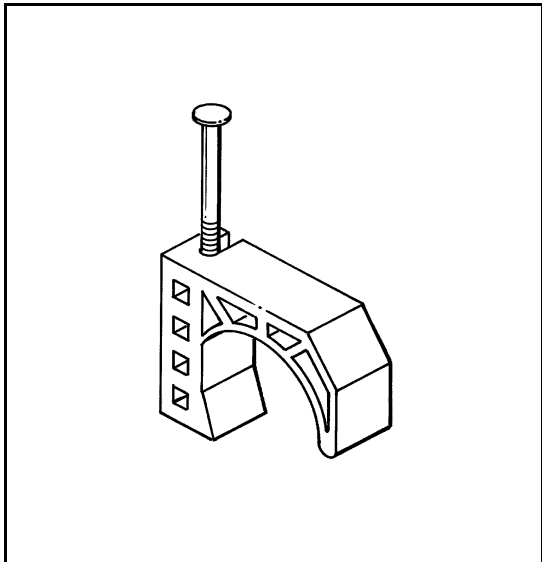

TUBE CLAMP Specification Sheet

PART NO.	DESCRIPTION	MSTR CTN QTY/LBS
P-40429	TC 3/8"	1000/8
P-40433	TC 1/2"	5000/36
P-40434	TC 3/4"	2500/32
P-40435	TC 1"	1200/33

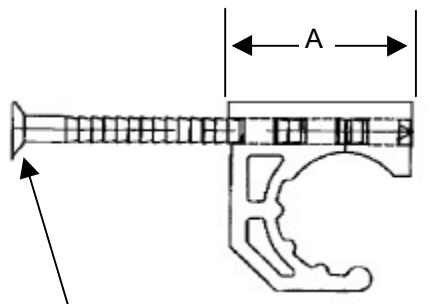

Ring-Shank Nail

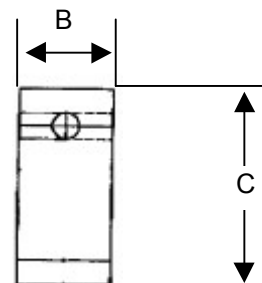

SPECIFICATION

Furnish and install Tube Clamp as manufactured by LSP Products Group/Specialty Products.

DESIGN FEATURES

- Constructed of high-impact plastic.
- Fast and easy to use.
- Pre-installed barbed nail prevents backout
- Black in color.

COMPLIANCES/LISTINGS

- IAPMO File #2139

Part Number	A	B	C
P-40429	7/8"	3/8"	3/4"
P-40433	1"	3/8"	7/8"
P-40434	1-3/8"	7/16"	1-1/8"
P-40435	1-3/4"	1/2"	1-1/2"



3689 Arrowhead Drive, Carson City, NV 89706
 Phone (800) 854-3215 Fax (800) 243-1777
 E-mail sales@lspproducts.com Website www.lspproducts.com

Content matter is subject to change at any time. It is the user's responsibility to ensure the most updated revisions are obtained.

SP/S-2024 (03-02) Rev 1

Product Submittal	
Job Name	
Date	
Part Number	Quantity
Architect	
Contractor	