

Specialty Products™

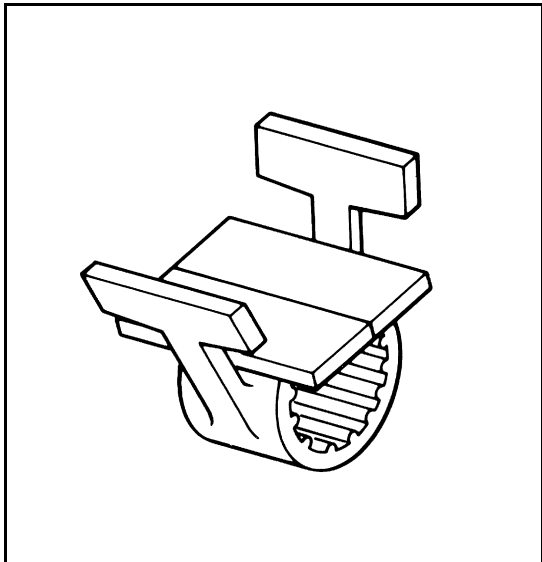

STRUT CLAMP Specification Sheet

PART NO.	DESCRIPTION	MSTR CTN QTY/LBS
P-2041	STC 1/2"	1200/31
P-2042	STC 3/4"	900/28
P-2043	STC 1"	600/22
P-2044	STC 1-1/4"	600/33
P-2045	STC 1-1/2"	500/30
P-2046	STC 2"	300/24

SPECIFICATION

Furnish and install Strut Clamp as manufactured by LSP Products Group/Specialty Products.

DESIGN FEATURES

- Designed to work with channel bar.
- Completely encircles pipe.
- No tools needed for installation.
- Fits 1-5/8" track
- Black in color.
- For use with all types of pipe.

COMPLIANCES/LISTINGS

- IAPMO File #2139



3689 Arrowhead Drive, Carson City, NV 89706
 Phone (800) 854-3215 Fax (800) 243-1777
 E-mail sales@lspproducts.com Website www.lspproducts.com

Content matter is subject to change at any time. It is the user's responsibility to ensure the most updated revisions are obtained.

SP/S-2023 (03-02) Rev 1

Product Submittal	
Job Name	
Date	
Part Number	Quantity
Architect	
Contractor	